Fédération Internationale
de Basketball



FIBA

International Basketball
Federation

We Are Basketball

Official Basketball Rules 2004

Basketball Equipment

As approved by

FIBA Central Board

Paris, France, 12th June 2004

Valid as of 1st September 2004



TABLE OF CONTENTS

1	Backstop unit	6
2	Backboard	6
3	Basket ring	8
4	Basket net	10
5	Backboard support structure	10
6	Padding	11
7	Basketballs	11
8	Game clock	12
9	Scoreboard	13
10	Twenty-four second device	14
11	Signals	15
12	Player foul markers	15
13	Team foul markers	15
14	Alternating possession indicator	16
15	Playing floor	16
16	Playing court	17
17	Lighting	18
18	Advertising boards	19
19	Support service areas	20
20	Spectator areas	20
21	References	21



Basketball Equipment

Throughout Basketball Equipment, all references made to a timekeeper, scorekeeper, twenty-four second operator, etc. in the male gender also apply to the female gender. It must be understood that this is done for practical reasons only.

Introduction

The Basketball Equipment section of the Official Basketball Rules specifies all basketball equipment required at a game. Reference to high level competitions indicates that the equipment is imperative for this level and strongly recommended for medium level and all the other competitions. Reference to medium level competitions indicates that the equipment is imperative for this level and strongly recommended for all other competitions.

This appendix shall be used by all parties involved directly in the game as well as by basketball equipment manufacturers, local organisers and FIBA for its equipment approval programme and to establish national and international standards.

The competitions are divided into three levels:

- High level competitions (Level 1):
Main FIBA official competitions, as defined in Art. 1.1.1 of the FIBA Internal Regulations governing the FIBA Competitions.
The facilities and equipment required for the following main FIBA official competitions are subject to FIBA approval (Levels 1 and 2): Olympic Tournaments; World Championships for Men, Women, U-21 and U-19; Zone Championships for Men, Women and U-20.
All equipment at these competitions must be FIBA approved and must display the FIBA logo in the FIBA approved layout.
- Medium level competitions (Level 2):
All other FIBA official competitions as defined in Art. 1.1.2 and 1.1.3 of the FIBA Internal Regulations governing the FIBA Competitions, and high level competitions of the national federations.
- Other competitions (Level 3):
All other competitions not included in the above.

- Notes:**
1. All measurement tolerances are according to DIN ISO Standard 286 (see References [1]) except where other values are explicitly stated.
 2. Reference is made to the FIBA publications "Guide to Basketball Facilities for High-Level Competitions" and "Guide to Small Basketball Facilities".

1 Backstop unit

There will be two (2) backstop units (Diagram 1), one placed at each end of the playing court and each consisting of the following parts:

- One (1) backboard.
- One (1) basket ring with a ring mounting plate.
- One (1) basket net.
- One (1) basket support structure.
- Padding.

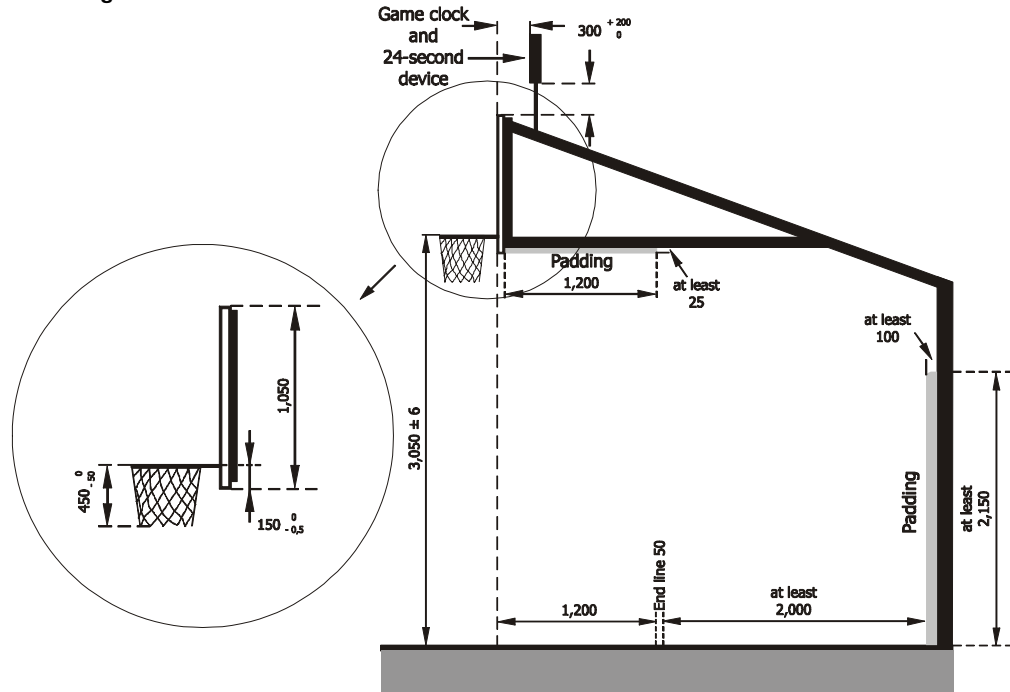

Diagram 1 Backstop unit

2 Backboard

2.1 The backboards shall be made of a suitable transparent material (for Level 1 and 2, of a tempered safety glass), made in one piece, non reflective, with flat front surface and shall:

- Have a protective framework of the backboard support structure around the outside edge.
- Be manufactured such that, if broken, the pieces of glass do not split off.

2.2 For Level 3, the backboards may be made of other material(s) painted white, but must meet the other specifications above.

2.3 The backboards shall measure 1,800 mm (+ a maximum of 30 mm) horizontally and 1,050 mm (+ a maximum of 20 mm) vertically.

2.4 All lines on the backboards shall be:

- In white, if the backboards are transparent.
- In black, if white painted backboards are non-transparent.
- 50 mm in width.

2.5 The borders of the backboards shall be marked with a boundary line (Diagram 2) and an additional rectangle behind the ring as follows:

- Outside dimensions: 590 mm (+ a maximum of 20 mm) horizontally and 450 mm (+ a maximum of 8 mm) vertically.
- The top edge of the base of the rectangle shall be level with the top of the ring and 150 mm (- 2 mm) above the bottom edge of the backboard.

- 2.6 For Level 1, each backboard shall be equipped with lighting around its perimeter, mounted on the inside borders of the backboards and which lights up in red when the game clock signal sounds for the end of a period.

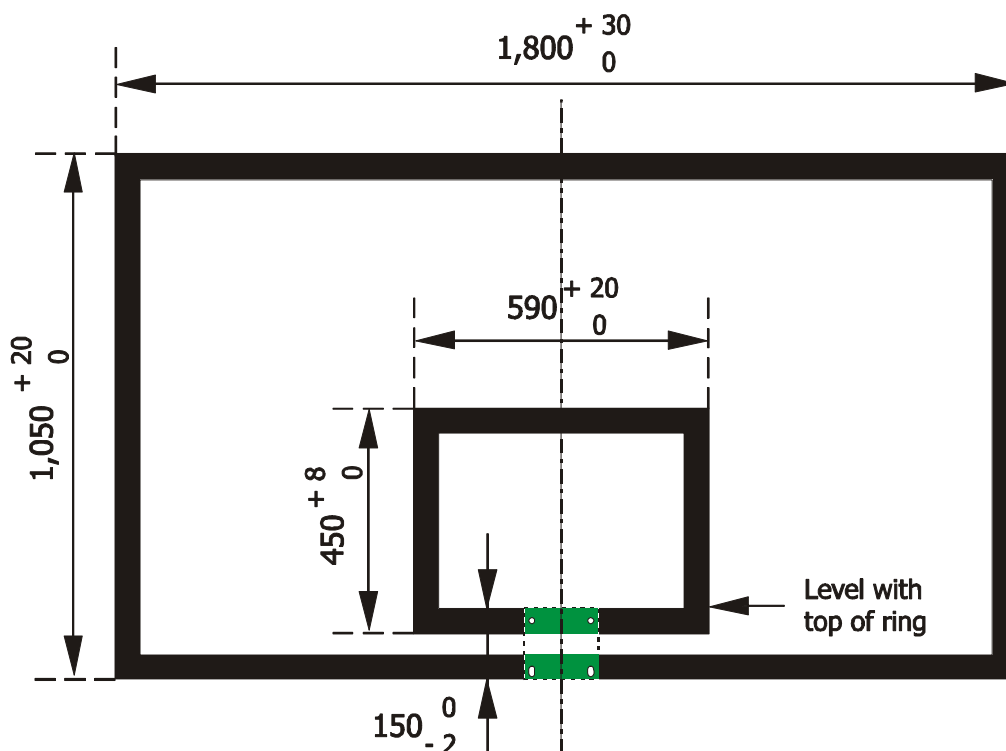

Diagram 2 Backboard markings

- 2.7 The backboards shall be firmly mounted on the backboard support structures at each end of the playing court at right angles to the floor, parallel to the endlines (Diagram 1). The central vertical line on their front surfaces, extended down to the floor, shall touch the point on the floor which lies 1,200 mm from the centre point of the inner edge of each endline, on an imaginary line drawn at right angles to this endline.
- 2.8 Test of the rigidity of backboard tempered safety glass:

- When a square-shaped weight of 50 kg (250 mm wide and high, and 1,100 mm long) is applied along the centre of the backboard glass (without its frame), which is placed horizontally on two parallel wooden bars at a distance of 1,200 mm from each other (Diagram 3), the maximum vertical deformation shall be 3 mm.

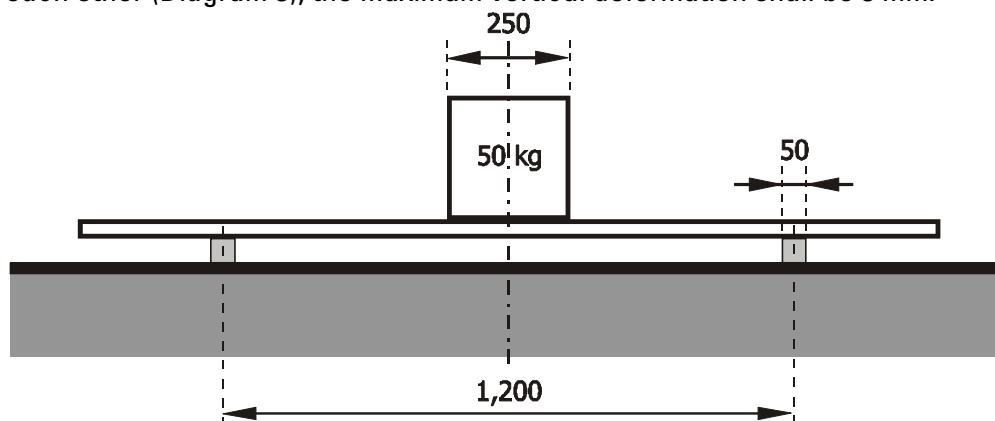
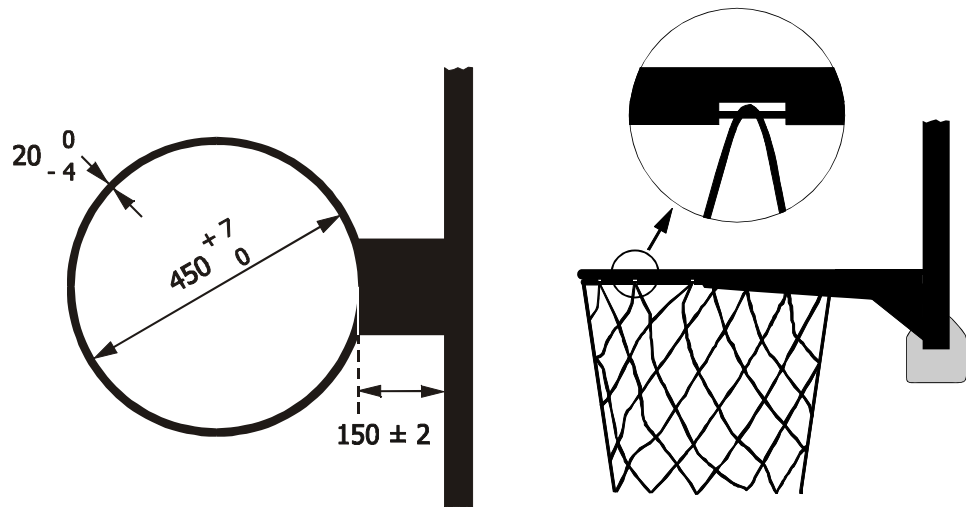

Diagram 3 Rigidity of the backboard glass

- When a basketball is dropped onto the backboard, it shall rebound from it with a minimum rebounding height of 50%.

3 Basket ring

- 3.1 The rings shall be made of a solid steel and shall:
- Have an inside diameter of a minimum of 450 mm and a maximum of 457 mm.
 - Be painted orange within the following Natural Colour System (NCS) FIBA approved spectrum (see References [2]):
0080-Y70R 0090-Y70R 1080-Y70R
 - Have its metal a minimum of 16 mm and a maximum of 20 mm in diameter.
- 3.2 The net shall be attached to each ring in 12 places. The fittings for the attachment shall not:
- Have any sharp edges or gaps,
 - Have gaps smaller than 8 mm, to prevent fingers from entering,
 - Be designed as hooks for Level 1 and 2.



Attachment of the net (example)

Diagram 4 Basket ring

- 3.3 The rings shall be fixed to the backboard support structures in such a way that any force applied to the ring cannot be transferred to the backboard itself. Therefore, there shall be no direct contact between the ring mounting plate and the backboard (Diagram 5).
- 3.4 The top edge of each ring shall be positioned horizontally, 3,050 mm (\pm a maximum of 6 mm) above the floor, equidistant from the two vertical edges of the backboard.
- 3.5 The point on the inside circumference of the ring nearest the backboard shall be 150 mm (\pm a maximum of 2 mm) from the face of the backboard.

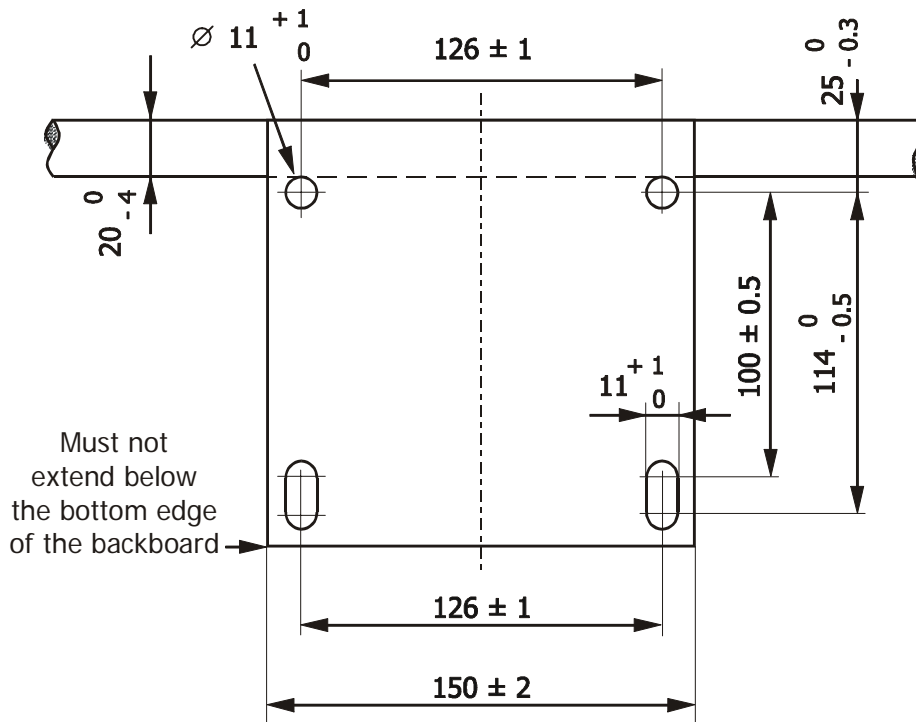

Diagram 5 Ring mounting plate

- 3.6 For existing basket support structures, it is recommended that the ring mounting plate be fixed to the framework according to the measurements given in Diagram 6.

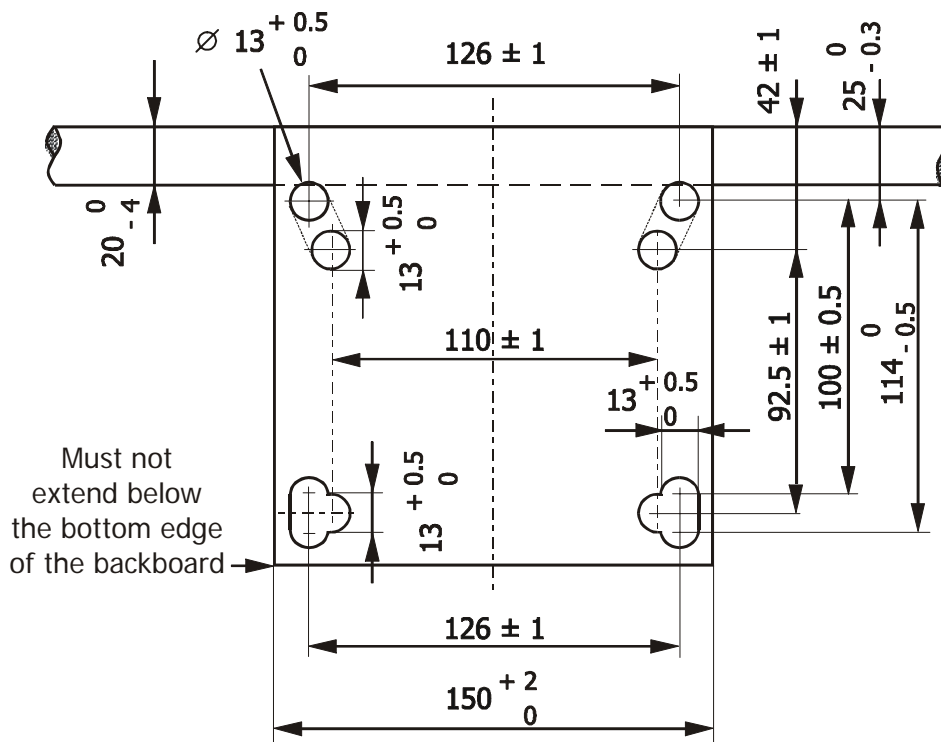

Diagram 6 Ring mounting plate for existing baskets

- 3.7 Pressure release rings with the following specifications may be used:
- It shall have rebound qualities close to those of the fixed ring. The pressure release mechanism shall ensure these characteristics, but not cause any damage to either the ring or the backboard. The design of the ring and its construction shall be such that the players' safety is ensured.



- The pressure release rings with a 'positive-lock' mechanism must not disengage until a static load of 82 kg minimum and 105 kg maximum has been applied vertically to the top of the ring at the most distant point from the backboard.
 - When the pressure release mechanism is released, the front or the side of the ring shall rotate no more than 30 degrees and no less than 10 degrees below the original horizontal position.
 - After release, and with the load no longer applied, the ring shall return automatically and instantly to its original position. No fissures and no permanent deformation of the ring should be observed.
 - Both rings must have identical rebound characteristics.
- 3.8 For Level 1, only the FIBA approved test device for measuring the correct height and the rebound/elasticity of the ring may be used.
The rebound/elasticity of the ring and support system should be within 35% - 50% energy absorption range of total impact energy and with a 5% differential between both baskets on the same playing court.
For Level 2 and 3 the FIBA approved test device should be used regularly, at least two (2) times a year.

4 Basket net

- 4.1 The nets shall be made of white cord and shall be:
- Suspended from the rings.
 - Manufactured so that they check the ball momentarily as it passes through the basket.
 - No less than 400 mm and no more than 450 mm in length.
 - Manufactured with 12 loops to attach it to the ring.
- 4.2 The upper section of the net shall be semi-rigid to prevent:
- The net from rebounding up through the ring, creating possible entanglement.
 - The ball from becoming trapped in the net or rebounding back out of the net.

5 Backboard support structure

- 5.1 For Level 1, only mobile or floor-fixed backboard support structures shall be used.
For Levels 2 and 3, ceiling or wall mounted backboard support structures may also be used. Ceiling mounted backboards shall not be used in sports halls with a suspension height exceeding 10,000 mm.
- 5.2 The backboard support structure shall be:
- At a distance of at least 2,000 mm, including padding, from the outer edge of the endline (Diagram 1).
 - Of a bright colour, contrasting with the background, so that it is clearly visible to the players.
 - Secured to the floor so as to prevent any movement. Should floor anchoring be not possible, an additional weight on the basket support base must be used to prevent any movement.
 - Adjusted such as that once the top edge of the ring is at a height of 3,050 mm from the playing floor, this height shall not be changed.
- 5.3 The rigidity of the backboard support structure with ring shall fulfil the requirements of the EN 1270 norms.
- 5.4 The visible vibration of the backboard support unit shall end within a maximum of four (4) seconds after a dunk shot.

6 Padding

- 6.1 The backboard and backboard support structure must be padded.
- 6.2 The padding of the backboard shall cover, with a minimum thickness of 20 mm (Diagram 7):
- The bottom and vertical edges on each side, to a minimum height of 350 mm from the bottom.
 - The lower edges of both the front and the back surfaces of the backboards, to a minimum height of 20 mm from the bottom.
- 6.3 The padding of the backboard support structure shall cover:
- The vertical edges on each side, to a minimum height of 2,150 mm from the floor and with a minimum thickness of 100 mm (Diagram 1).
 - The bottom and side surfaces of the supporting arm of the backboard, from the back surface of the backboard over a minimum length of 1,200 mm along the arm, with a minimum thickness of 25 mm (Diagram 1).
- 6.4 All padding shall:
- Be constructed so as to prevent limbs from being trapped.
 - Have a maximum indentation factor of 50%. This means that when a force is applied suddenly to the padding, the indentation in the padding does not exceed 50% of its original thickness.
 - Pass the test according to EN 913, Annex C (see References [3]).
 - Be blue in colour according to NCS 0090-B10G, for Level 1.

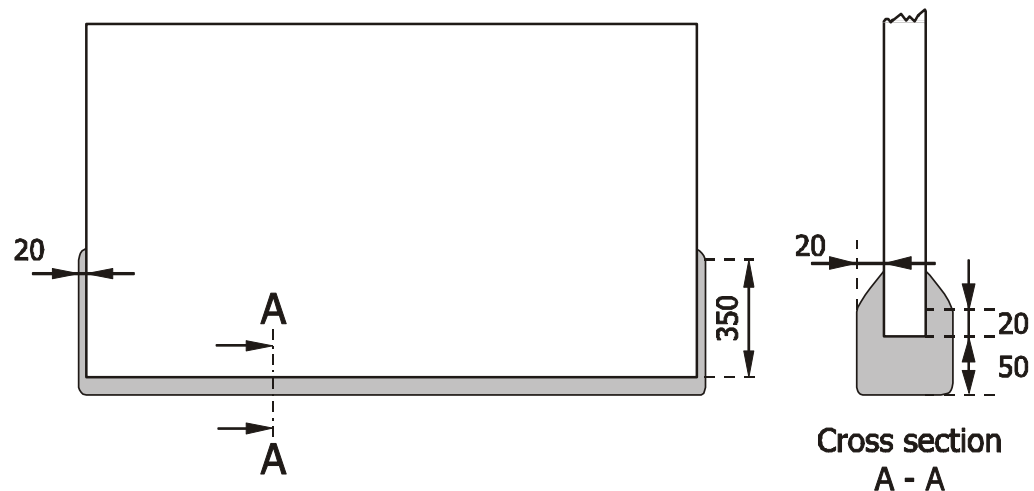

7 Basketballs

- 7.1 For Levels 1 and 2, the outer surface of the ball shall be made of leather or artificial/-composite/synthetic leather.
For Level 3, the outer surface of the ball may be made of rubber.
- 7.2 The surface of the ball shall not contain toxic materials or any materials which may cause an allergic reaction. The ball must not contain heavy metals (EN 71) or AZO colours.
- 7.3 The ball shall:
- Be spherical, with black seams and, either of a single shade of orange or of the orange/light brown FIBA approved colour combination (Diagram 8).
 - Have either eight (8) or twelve (12) seams, not exceeding 6.35 mm in width (Diagram 8).

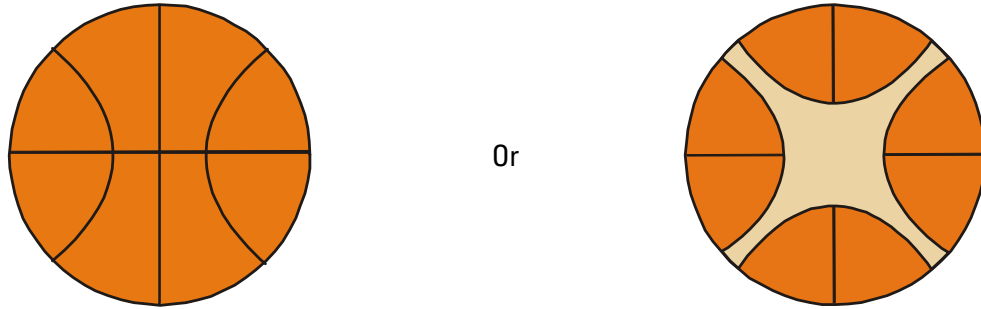

Or

Diagram 8 Basketballs

- Be inflated to an air pressure such that, when it is dropped onto the playing floor from a height of approximately 1,800 mm measured from the bottom of the ball, it will rebound to a height of between 1,200 mm and 1,400 mm, measured to the top of the ball.
 - Be marked with its respective size number.
- 7.4 For all men's competitions in all categories, the circumference of the ball shall be no less than 749 mm and no more than 780 mm (size 7) and the ball shall weigh no less than 567 g and no more than 650 g.
- 7.5 For all women's competitions in all categories, the circumference of the ball shall be no less than 724 mm and no more than 737 mm (size 6) and the ball shall weigh no less than 510 g and no more than 567 g.
- 7.6 In addition to checking the specifications listed above, the following tests shall be carried out:
- Fatigue strength test.
 - Heat-storage test.
 - Valve leak test.
 - Practice test.
 - For Levels 1 and 2, the category 1 ball "black" test.
- 7.7 For Levels 1 and 2, the organisers shall provide at least 12 balls of the same make and specification for practices and warm-ups.

8 Game clock

- 8.1 For Levels 1 and 2, the main game clock (Diagram 9) shall:
- Be a digital countdown clock with an automatic signal sounding for the end of the period as soon as the display shows zero (00:00).
 - Have the ability to indicate time remaining in minutes and seconds and tenths (1/10) of seconds at least during the last minute of the period.
 - Be placed so that it is clearly visible to everyone involved in the game, including the spectators.
- 8.2 If the main game clock is placed above the centre of the playing court, there shall be a synchronised duplicate game clock at each end of the playing court, each of which must be high enough that it is clearly visible to everyone involved in the game, including the spectators. Each duplicate game clock shall display the score and the playing time remaining throughout the game.
- 8.3 For Levels 1 and 2, a whistle-controlled time system, interfaced with the connector equipped game clock shall be used by the officials to stop the game clock, provided that this system is used in all the games of a given competition. The officials shall also start the game clock, however this is, at the same time, also done by the timekeeper. All FIBA approved scoreboards shall provide the interface with the whistle controlled system.

9 Scoreboard

- 9.1 For Levels 1 and 2, two (2) large scoreboards shall be:
- Placed, one at each end of the playing court and, if so desired, a further scoreboard (cube) placed above the centre of the playing court. This does not exclude the need for the other two scoreboards.
 - Clearly visible to everyone involved in the game, including the spectators.
- 9.2 A game clock control panel shall be provided for the timekeeper and a separate scoreboard control panel shall be provided for the assistant scorekeeper. The control panels cannot be computer keyboard panels. Each panel shall enable easy correction of any incorrect data and have memory back-ups to save all game data for a minimum of thirty (30) minutes.
- 9.3 The scoreboard shall include and/or indicate:
- The digital countdown game clock.
 - The points scored by each team, and for Level 1 the cumulative points scored by each individual player.
 - The number of each individual player, and for Level 1 and their corresponding surnames.
 - The team's names.
 - The number of fouls committed by each player on the team from 1 to 5. The fifth foul shall be indicated in red or orange. The number may be shown with five (5) indicators or a number display with a minimum height of 135 mm. In addition, the 5th foul may be indicated with a slow flashing display (~ 1 Hz) for five (5) seconds.
 - The number of team fouls from 1 to 5, stopping at 5.
 - The number of the period from 1 to 4, and E for an extra period.
 - The number of charged time-outs per half from 0 to 3.
 - The team for the throw-in at the next alternating possession jump ball situation.
 - A clock for timing the time-out (optional). The game clock must not be used for this purpose.
- 9.4 For Levels 1 and 2:
- The display on the scoreboard shall be in bright contrasting colours.
 - The background of the display shall be antiglare.
 - The display numbers on the game clock and game score shall be a minimum height of 300 mm and a minimum width of 150 mm.
 - The display numbers of team fouls and periods shall be a minimum height of 250 mm and a minimum width of 125 mm.
 - The scoreboard game clock, game score and the twenty-four second device should have a minimum viewing angle of 130°.
- 9.5 The scoreboard shall:
- Not have any sharp edges or burrs.
 - Be mounted securely.
 - Be able to withstand severe impact from any ball.
 - Have specific protection, if necessary, which should not impair the readability of the scoreboard.
 - Have electromagnetic compatibility in accordance with the statutory requirements of the respective country.

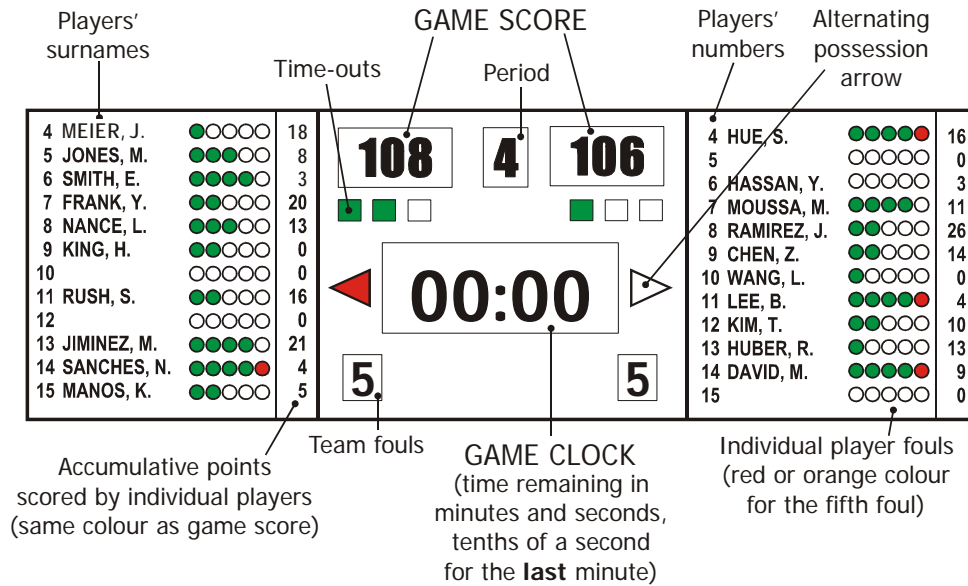

Diagram 9 Scoreboard for Level 1 (example of the layout)

10 Twenty-four second device

10.1 The twenty-four second device shall have:

- A separate control unit provided for the twenty-four second operator, with a very loud automatic signal to indicate the end of the twenty-four second period when the display shows zero (0).
- A display unit with a digital countdown, indicating the time in seconds.

10.2 The twenty-four second device shall have the ability to be:

- Started from twenty-four (24) seconds.
- Stopped with the display indicating the seconds remaining.
- Restarted from the time at which it was stopped.
- Showing no display, if necessary.

10.3 The twenty-four second device shall be connected to the game clock so that when:

- The game clock stops, the device shall also stop.
- The game clock starts, it is possible to start the device manually.
- The device stops and sounds, the game clock count continues and may be stopped, if necessary, manually.

10.4 The twenty-four second device display unit (Diagram 10), together with a duplicate game clock and a red light shall:

- Be mounted on each backboard support structure a minimum of 300 mm above and behind the backboard (Diagram 1) or hung from the ceiling.
- Have the different colours of the numbers of the twenty-four second device and the duplicate game clock.
- Have the numbers of the twenty-four second display a minimum height of 230 mm and be larger than the numbers of the duplicate game clock.
- For Level 1, have a minimum of three (3) display surfaces per unit (recommended for Level 2 and 3) to be clearly visible to everyone involved in the game, including the spectators.
- Have the maximum weight of the three-sided twenty-four second device, including the support structure, not exceeding 80 kg.
- Pass the test of protection against damage by balls according to DIN 18032-3 (see References [8]).
- Have electromagnetic compatibility in accordance with the statutory requirements of the respective country.

- 10.5 The electric light on the twenty-four second device display unit shall be:
- Of a bright red colour.
 - Synchronised with the game clock to light up when the signal sounds for the end of playing time for a period.
 - Synchronised with the twenty-four second device to light up when the signal sounds for the end of a twenty-four second period.

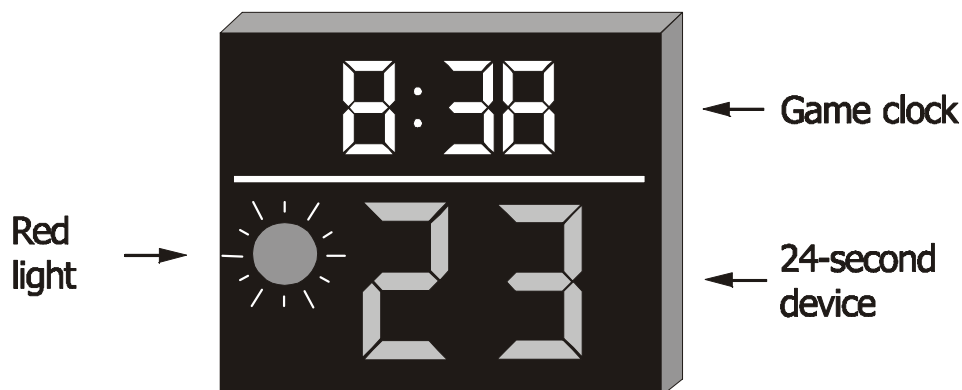

Diagram 10 Twenty-four second device display unit, duplicate game clock, and red light for Levels 1 and 2 (example of the layout)

11 Signals

- 11.1 There shall be at least two (2) separate sound signals, with distinctly different and very loud sounds:
- One (1) provided for the timekeeper and the scorekeeper which shall sound automatically to indicate the end of the playing time for a period. The timekeeper and scorekeeper shall be able to sound the signal manually when appropriate to attract the attention of the officials.
 - One (1) provided for the twenty-four second operator which shall sound automatically to indicate the end of the twenty-four second period.
- 11.2 Both signals shall be sufficiently powerful to be easily heard above the most adverse or noisy conditions. The sound volume shall be adjustable, according to the size of the sport hall and the noise of the crowd, to a maximum sound pressure level of 120 dBA measured at a distance of one (1) m from the source of the sound. A connection to the public information system of the sports hall is strongly recommended.

12 Player foul markers

The five (5) player foul markers provided for scorekeeper shall be:

- Of white colour.
- With numbers a minimum of 200 mm in length and 100 mm in width.
- Numbered from 1 to 5 (1 to 4 in black and the number 5 in red).

13 Team foul markers

13.1 The two (2) team foul markers provided for scorekeeper shall be:

- Of red colour.
- A minimum of 350 mm in height and of 200 mm in width.
- Clearly visible to everyone involved in the game, including the spectators, when positioned on either side of the scorer's table.
- Used to indicate the number of team fouls up to five (5) and to show that a team has reached the team foul situation.

13.2 Electrical or electronic devices may be used but they shall meet the above specifications.

14 Alternating possession indicator

- 14.1 The alternating possession indicator (Diagram 11) provided for the scorekeeper shall:
- Have an arrow of a minimum length of 100 mm and height 100 mm.
 - Display on the front side an arrow, illuminated in bright red colour when switched on, showing the direction of the alternating possession.
 - Be positioned in the centre of the scorer's table and shall be clearly visible to everyone involved in the game, including the spectators.
- 14.2 For Level 1, the scoreboard shall include an alternating possession indicator (Diagram 9).

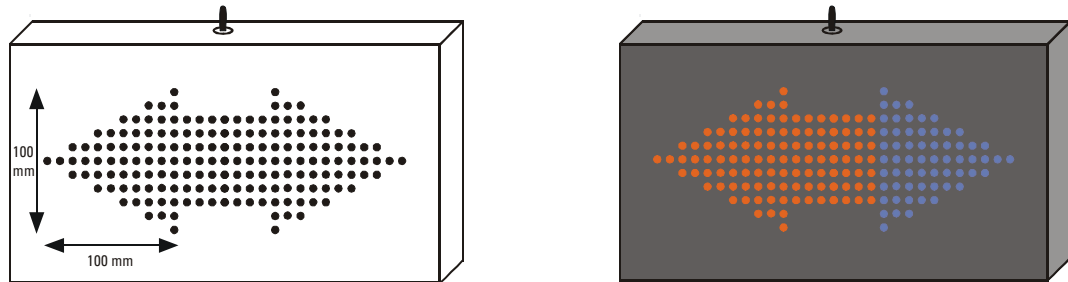

Diagram 11 Alternating possession indicator
(Example of the layout)

15 Playing floor

- 15.1 The playing floor surface shall be made of:
- Permanent wooden flooring (Levels 1 and 2).
 - Mobile wooden flooring (Levels 1 and 2).
 - Permanent synthetic flooring (Levels 2 and 3).
 - Mobile synthetic flooring (Levels 2 and 3).
- 15.2 The playing floor shall:
- Be a minimum length of 32,000 mm and a minimum width of 19,000 mm.
 - Have an antiglare surface.
 - For Level 1, permanent wooden flooring, meet DIN 18032-2 (see References [7]).
- 15.3 The manufacturer, together with the flooring installation company, shall be obliged to produce documentation for each customer comprising at least the following: results of the prototype test, a description of the installation procedure, results of the inspection and approval of the existing installation carried out by approved inspection officials.
- 15.4 The height of the ceiling or the lowest obstruction above the playing floor shall be at least seven (7) m.

16 Playing court

16.1 The playing court shall be marked by:

- 50 mm lines, as per the Official Basketball Rules.
- A further boundary line (Diagram 12), in a sharply contrasting colour and having a minimum width of 2,000 mm.

The colour of the further boundary line must be the same as that of the centre circle and the restricted areas.

16.2 The scorer's table, a minimum of 6,000 mm in length and 800 mm in height, must be placed on a platform, a minimum of 200 mm in height.

16.3 All spectators must be seated at a distance of at least 5,000 mm from the outside edge of the boundary lines of the playing court.

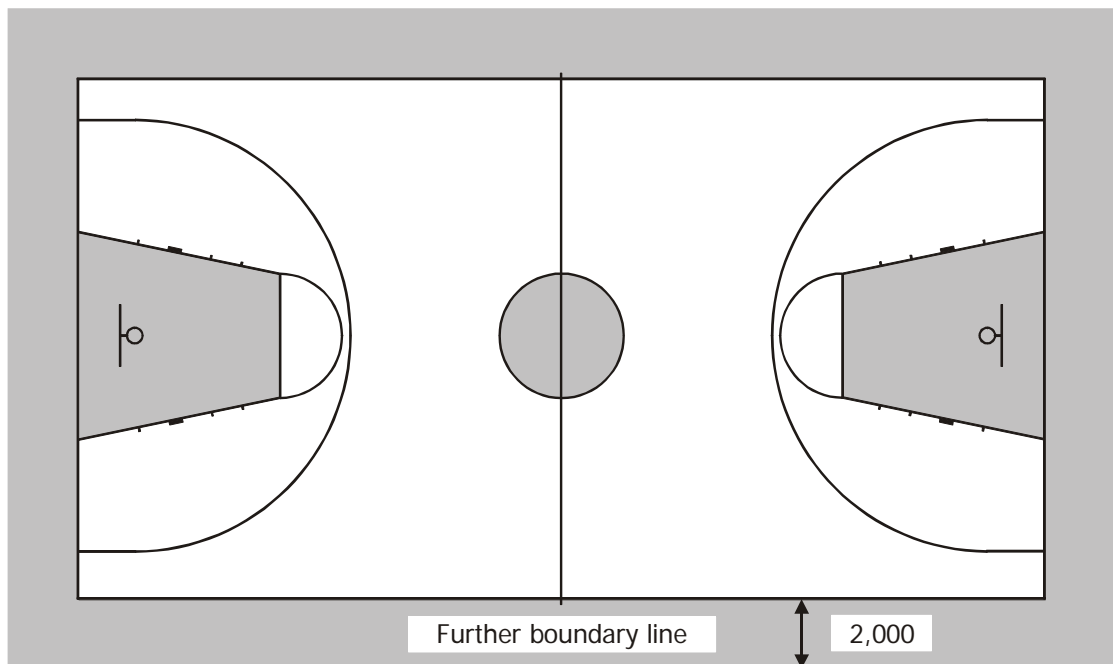

Diagram 12 Playing court



17 Lighting

- 17.1 The playing court shall be uniformly and adequately lit. The lights shall be positioned so they do not hinder the players' and officials' vision.
- 17.2 The table below defines the lighting levels for FIBA televised events. These levels shall be measured 1,500 mm above the playing court.

Competitions	Luminance – E (lux)			Uniformity		Lamps / colour	
	Description	E _{ave.}	U.G % / 2m	U1 E _{min.} / E _{max.}	U2 E _{min.} / E _{ave.}	Colour ³ Tempera- ture Tc	Colour Rendering CRI / Ra
Level 1	Slo-mo ¹ E _{cam.FOV}	1,800	5	0.5	0.7	3,000 ≤ 6,000	≥90
	SDTV ² E _{cam.FOV}	1,400	5	0.5	0.7		
	HORI- ZONTAL	1,500-3,000	5	0.6	0.7		
Level 2	SDTV ² E _{cam.FOV}	1,400	5	0.5	0.7	3,000 ≤ 6,000	≥90
	HORI- ZONTAL	1,500-2,500	5	0.6	0.7		
Level 3	E _{cam.FOV}	1,000	10	0.5	0.6	3,000 ≤ 6,000	≥80
	HORI- ZONTAL	1,000-2,000	10	0.6	0.7		
<p>Notes</p> <ol style="list-style-type: none"> Slo-mo refers to triple frame rate slow motion cameras. SDTV refers to Standard Definition Television cameras. Photographers using reversal film (5,500 K) will prefer light sources having a colour temperature between 5,500 K and 6,000 K (DIN EN 12193, see References [6]). 							
<p>Glossary</p> <ul style="list-style-type: none"> Ecam The light in the direction of a specific camera location. FOV The intended field of view of a camera Ecam. Eave The average illumination either horizontal or toward a camera Ecam. UG Uniformity Gradient, the percentage difference of illumination between adjacent grid points. Grid The basic layout of measuring and calculation points for FIBA basketball events. 							

- 17.3 All lighting installations shall:
- Reduce glare and shadows by being correctly positioned.
 - Be in accordance with the national safety requirements for electrical equipment in the respective country.
 - Provide Level 3 conditions in the event of a power failure.
- 17.4 For Level 1, the strobe light system shall have:
- A wiring harness for the installation of four lines, one in each corner of the playing court.
 - Each line with the ability to power a set of four strobe lights.
 - Each set with synchro-cabling and accessibility for the photographers via a switch exchange located in the vicinity of the basket support structure.
 - Each set located at a distance of at least 5,000 mm from the boundary line and at a height of 15,000 mm (recommended).

- Four sockets for the strobe lights located 2,000 mm from the flashes. Each socket shall be separate and protected against interference between the lamps (thermal recognition differential magnet).
- The harness installed safely and out of the reach of the spectators.
- The flashes installed safely to prevent them from falling.

17.5 Individual flash photography is not permitted.

18 Advertising boards

18.1 Advertising boards may be located around the playing court and:

- Shall be located at a minimum distance of 2,000 mm from the endlines and sidelines (Diagram 13).
- Those along the endlines must have a minimum gap of 900 mm on each side of the mobile backstop units so that the floor wiper(s) and portable TV camera(s) can pass through, if necessary.

18.2 Advertising boards are permitted in front of the scorer's table provided that they are placed directly in front of and flush with the table.

18.3 Advertising boards shall:

- Not exceed a height of 1,000 mm from the playing court.
- Be padded around the top with a minimum thickness of 20 mm.
- Have no burrs and all edges shall be rounded off.
- Be in accordance with the national safety requirements for electrical equipment in the respective country.
- Have mechanical protection for all engine driven parts.
- Be non-flammable.

18.4 For Level 1, only motorised rotating advertising boards are permitted.

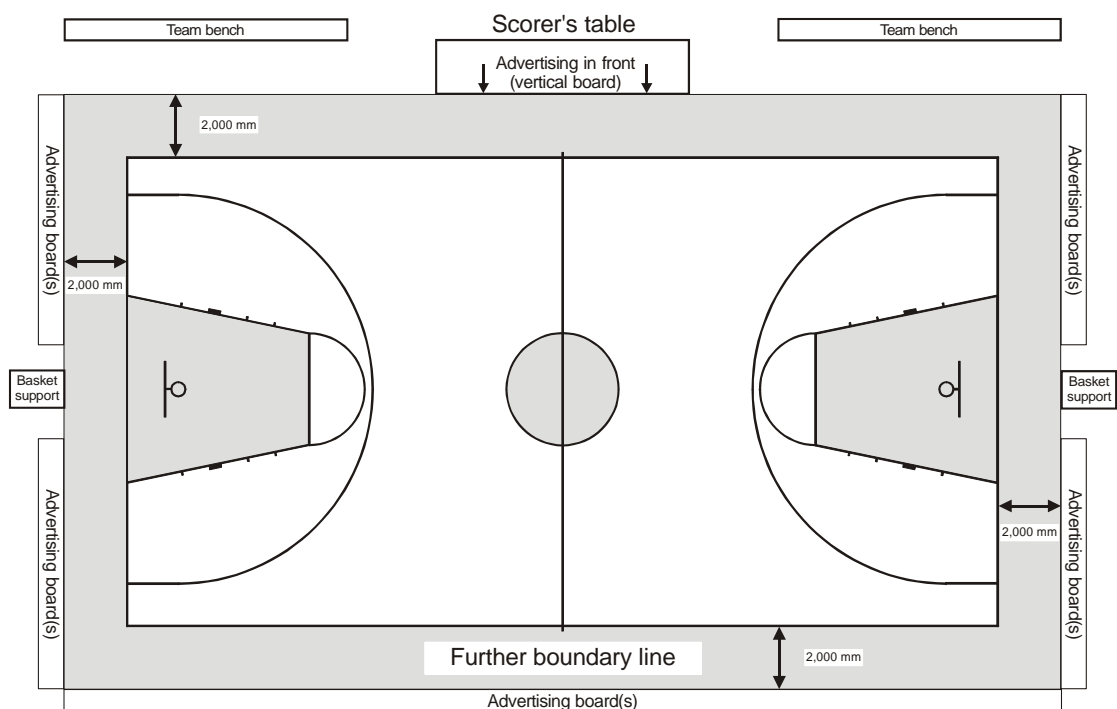

Diagram 13 Advertising in the playing court area

19 Support service areas

19.1 The support service areas, which must be fully accessible to persons with a disability, are the areas in which essential operations for the competition are carried out.

19.2 The required areas are:

- a) Changing rooms for teams.
- b) Changing rooms for referees and table officials.
- c) Rooms for commissioners and FIBA representatives.
- d) Doping control station.
- e) First aid station for players.
- f) Changing room for staff.
- g) Storage room and cloakroom.
- h) Administrative offices.
- i) Media area.
- j) VIP area.

20 Spectator areas

20.1 The spectator areas shall:

- Allow the free movement of the public, including persons with a disability.
- Enable spectators to have a comfortable view of the event.
- Have unobstructed lines of visibility from all seats, as shown in Diagram 14, unless the local standards allow for deviations.

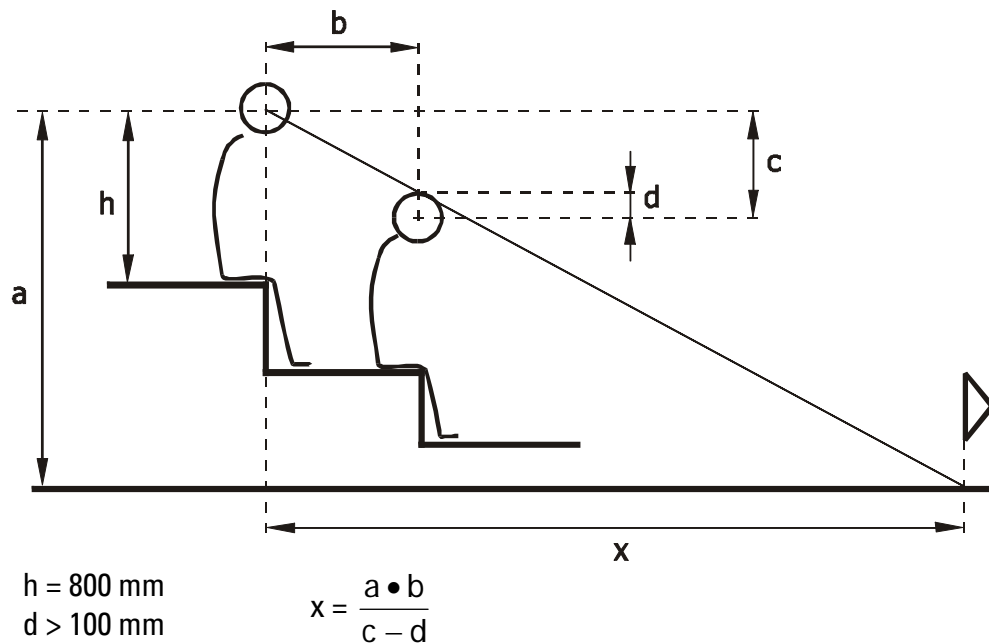

Diagram 14 Spectators' line of visibility

20.2 The seating capacity is defined as follows, unless the local standards allow for deviations:

- The total capacity of the sports hall is the sum of the seated and standing positions.
- The number of seated positions is the total number of seats or the total length of the terraces or benches in metres, divided by 480 mm.
- The number of standing positions is the assigned floor space, with 35 spectators on 10 m².

The above specifications are recommendations only.

21 References

- [1] DIN ISO 286, 1990: ISO system of limits and fits; bases of tolerances, deviations and fits
- [2] National Colour System of Standardiseringkommissionen i Sverige (SIS), Doc. No. SS019102
- [3] EN 913, Annex C, 1996: Determination of shock absorption of padding
- [4] EN 71-3, 1995: Safety of toys. Specification for migration of certain elements
- [5] EN 1270, 1998: Playing field equipment – Basketball equipment – Functional and safety requirements, test methods
- [6] DIN EN 12193, 1999: Lighting application, Sports lighting
- [7] DIN 18032-2, 1991: Sports hall surfaces, requirements, testing, maintenance
- [8] DIN 18032-3, 1997: Sport halls: halls for gymnastic and games: testing of safety against ball throwing
- [9] ISO 9002, 1994: Quality assurance management

ISO standards are sold by the ISO General Secretary in Geneva, Switzerland:

ISO Sales
Case Postale 56
1211 Genève 20
SUISSE
E-mail: sales@isocs.iso.ch

Standards from the European Committee for Standardisation (CEN) and national standards are available directly from the national standards bodies.